

NOTES

1. CONCRETE DRIVEWAY APRONS AND SIDEWALK CROSSINGS SHALL BE CONSTRUCTED OF CEMENT CONCRETE PAVEMENT (3000 PSI), 6" THICK REINFORCED WITH 6" X 6" #10/#10 WELDED WIRE FABRIC, (2" MINIMUM COVER FROM THE BOTTOM.)
2. FIBER REINFORCED CONCRETE 3000 PSI (MIN.) MAY BE USED IN PLACE OF THE REQUIREMENTS OF NO. 1 ABOVE.
3. CONSTRUCTION OF APRON/DRIVEWAY CROSS SLOPES AND SIDEWALK CROSS SLOPE THROUGH THE DRIVEWAY SHALL COMPLY WITH FDOT INDEX NO. 515 (SHEETS 3 & 4 OF 6) FOR ADA REQUIREMENTS.
4. REMOVE TREE ROOTS WITHIN 10" OF PROPOSED GRADE.
5. WHEN THERE IS EXISTING SIDEWALK CROSSING THE PROPOSED DRIVEWAY, IT MUST BE REMOVED TO THE NEAREST JOINT BEYOND THE DRIVEWAY.
6. SIDEWALKS ADJACENT TO LOT PROPERTY LINES SHALL NOT HAVE A CROSS SLOPE GREATER THAN 2% PER FDOT INDEX 310.
7. CORNER LOTS INVOLVING HANDICAP RAMPS SHALL BE IN ACCORDANCE WITH FDOT INDEX 304 FOR SIDEWALK AND RAMP CONSTRUCTION.
8. SPECIAL NOTE FOR ASSESSMENT PROJECTS ONLY: IF THE DISTANCE BETWEEN THE APRON AND THE EXISTING DRIVEWAY IS 2' -0" OR LESS, THE CONTRACTOR SHALL EXTEND APRON CONSTRUCTION TO CONNECT TO EXISTING DRIVEWAY (PAYABLE UNDER THIS CONTRACT). IF THIS DISTANCE IS GREATER THAN 2' -0", CONSTRUCTION OF THE DRIVEWAY SHALL BE AGREED UPON BY THE PROPERTY OWNER AND CONTRACTOR, AT THE PROPERTY OWNER'S EXPENSE.

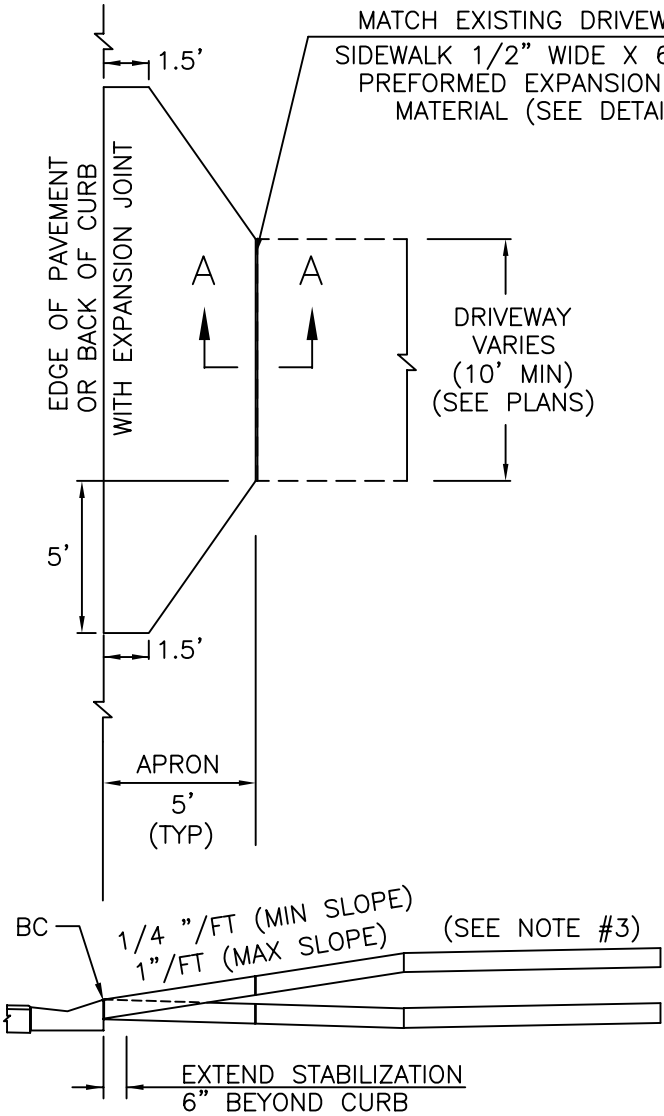

PLAN AND PROFILE VIEW

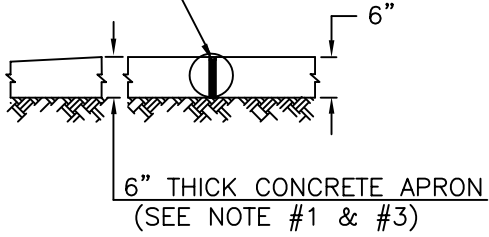

SECTION A-A

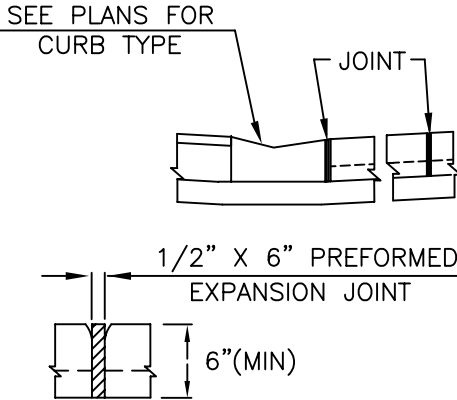

JOINT DETAIL

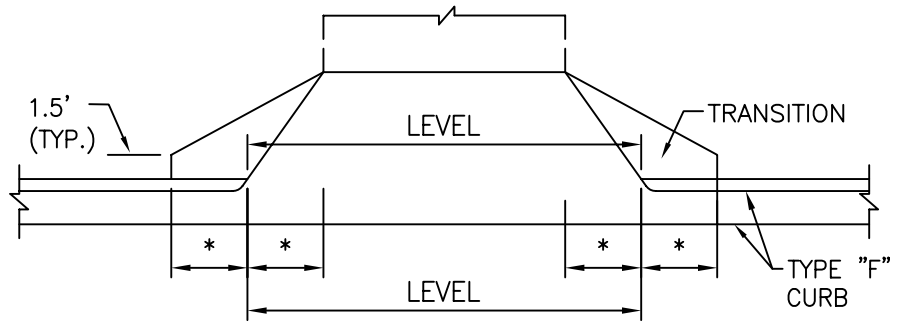

(\* SEE FDOT INDEX No. 515 FOR DIMENSIONS)

DEPARTMENT OF PUBLIC WORKS  
PINELLAS COUNTY, FLORIDA

**CONCRETE DRIVEWAY APRON**

APPROVED BY:	DATE	SHEET	INDEX
DIRECTOR OF PUBLIC WORKS	7/03	1 of 1	1340